

ALEXi

KEY SPECIFICATIONS

- High Quantum Efficiency
- Ultra Deep Cooling to -100°C
- 18-bit Dynamic Range
- Multi-MHz Readout
- Compact Design

Full-Frame Deep Cooling Scientific CCD Camera for Imaging Applications

Straight out of Berlin comes **ALEX**, greateyes' new platform for your spectroscopy applications in the VUV, EUV, soft and hard X-Ray range.

ALEX integrates cutting-edge low-noise electronics and ultra-deep cooling technology while keeping a compact camera design. Multiple readout speeds can be selected supporting pixel rates from 50 kHz up to 5 MHz.

True 18-bit AD conversion allows to exploit the full dynamic range of the CCD sensor for highest performance and SNR. **ALEX** is ideally suited for detection of very weak signal intensities where a low-noise floor is paramount.

ALEX offers unprecedented possibilities for your measurements of tomorrow.

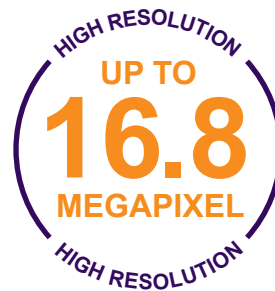

VUV

EUV

SXR

HXR

TYPICAL APPLICATIONS

- EUV Lithography
- X-ray Tomography
- Fourier Transform Holography
- X-ray Fluoroscopy
- Coherent Diffraction Imaging
- Ptychographic Spectromicroscopy
- Grazing-Incidence Small-Angle X-ray Scattering



Pembroke Instruments, LLC
San Francisco, California
sales@pembrokeinstruments.com
<https://pembrokeinstruments.com>
Tel. 650-550-8618

ALEXi

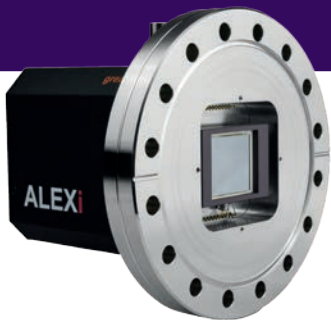

Berlin is unique for its character, and so is ALEX

The Berlin TV Tower (the tallest building in Germany) and the ALEX square below it, are symbols of Berlin and beloved by Berliners.



FEATURES & BENEFITS

Ultra deep TE cooling down to -100°C

lowest dark current for better detection limit

GigE & USB 3.0 data interface

local or remote network operation – your choice!

Fast readout speeds up to 5 MHz

fast frame rates paired with low-noise electronics

High QE up to 98%

very sensitive sensors for low light applications

User selectable gain

balance your detector for best SNR and dynamic range

Flexible software options

camera software and SDKs available

COMMON SPECIFICATIONS

Pixel readout frequency	50 kHz, 250 kHz, 1 MHz, 3 MHz (5 MHz for visualisation mode; up to 20 MHz with multi-output)
Readout modes	2 output nodes for 1k1k & 2k2k cameras, 4 output nodes for 2k2k plus & 4k4k cameras
AD converter resolution	18-bit
Linearity	Better than 99%
CCD epitaxial thickness	15 µm standard, 40µm for deep depletion (DD) models
Flange types	ISO-F DN63, knife-edge sealed CF DN63, CF DN100, CF DN160, CF DN200
Vacuum compatibility	With CF flange: 10 ⁻¹⁰ mbar (UHV capability)
Bakeout temperature	Max. +80°C
Flange - focal plane	1k1k camera with CF DN63: 6mm; 2k2k with CF DN63: 5mm; 2k2k plus & 4k4k cameras with CF DN160: -27mm (all distance can be customised)
Temperature monitoring	Two thermistors at CCD sensor and thermoelectric cooler (hot side)
Data link	Gigabit Ethernet, USB 3.0
Software	greateyes Vision software for Windows 7 / 10
SDK and drivers	DLL for Windows; LabVIEW, EPICS, Linux, Python, Tango driver (optional)
TTL interface signals	Sync out, shutter out, 2 external trigger in
Operating conditions	Temperature: 0°C to 35°C ambient, relative humidity <80% (non-condensing)
Power supply	1k1k & 2k2k: 80-264 VAC (typ. 115/230), 47-63 Hz (typ. 50/60), max. 1.1 A (230 V) / 1.9 A (115 V) 2k2k plus & 4k4k: 85-264 VAC (typ. 115/230), 47-63 Hz (typ. 50/60), max. 1.9 A (230 V) / 3.8 A (115 V)
Certification	CE
Dimensions (W x H x L)	1k1k & 2k2k Camera body: 8.3 cm x 10.0 cm x 10.9 cm (3.27" x 3.94" x 4.29") 2k2k plus & 4k4k Camera body: 13.7 cm x 13.7 cm x 13.3 cm (5.39" x 5.39" x 5.24")
Weight	2.9 kg (1k1k & 2k2k, CF DN63); 4.3kg (1k1k & 2k2k, CF DN100); 12.5kg (4k4k, CF DN160)

Included with your camera

GE-VI01	greateyes Vision software suite for Windows		
GE-SDK01	SDK for Windows (C/C++ based)	GE-StoB2m	2m SMB to BNC connection cable x2
GE-USB3m3	3m USB 3.0 cable type A to type C	GE-POW01	Camera power supply with cabling
GE-GigE10m	10m Ethernet cable	GE-ManCam	Camera instruction manual

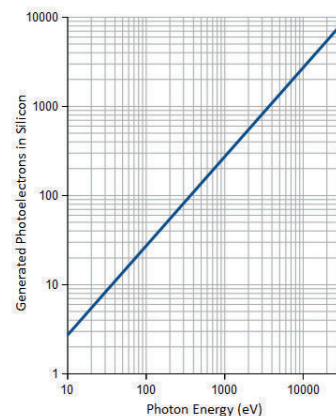
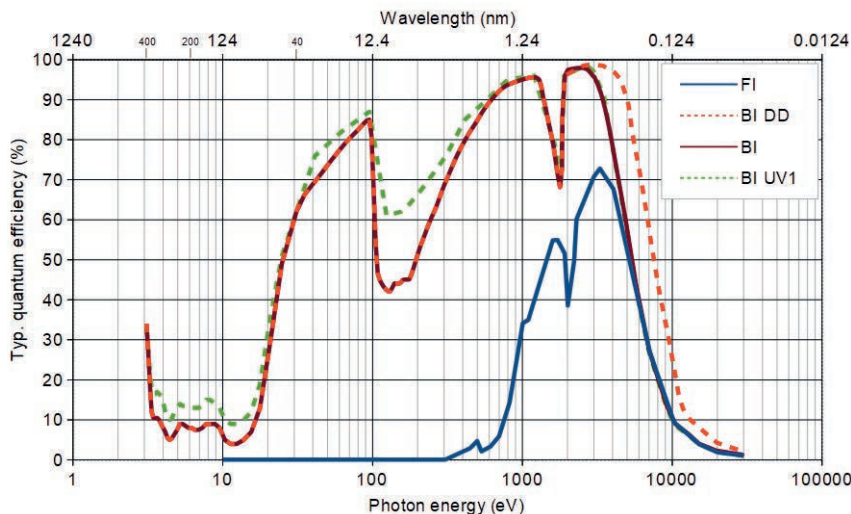

ALEXi

HIGH PERFORMANCE IMAGING CAMERAS



The mean energy of a photon to generate an electron-hole pair in silicon is 3.66 eV.

STEP 1: Choose your camera model

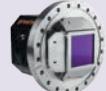
ALEXi Series				
Sensor code	FI BI BI DD BI UV1	FI BI DD BI UV1	BI	BI BI DD BI UV1
Usable pixels (columns x rows)	1024 x 1024 (FI) 1056 x 1027 (others)	2048 x 2052	2048 x 2064	4096 x 4112
Active image area	13.3 mm x 13.3 mm	27.6 mm x 27.6 mm	30.7 mm x 30.7 mm	61.4 mm x 61.4 mm
Pixel size	13 μm x 13 μm	13.5 μm x 13.5 μm	15 μm x 15 μm	15 μm x 15 μm
CCD sensor cooling	-100°C to 20°C	-90°C to 20°C	-90°C to 20°C	-90°C to 20°C
Full well capacity	100 ke ⁻ 120 ke ⁻	100 ke ⁻ 150 ke ⁻	150 ke ⁻	150 ke ⁻ 350 ke ⁻
Register well / Output node	400 ke ⁻ / -	400 ke ⁻ / - 600 ke ⁻ / -	- / 900 ke ⁻	- / 900 ke ⁻ - / 600 ke ⁻
Typical read noise (e⁻)				
@ 50 kHz	2.8	3.4	4.6	4.6 2.8
@ 1 MHz	6.4	7.0	8.5	8.5 5.8
@ 3 MHz	10.9	13.6	17.0	17.0 10.4
Dark Current (e ⁻ /pixels/s)	@ -100°C 0.00015 0.0005	@ -90°C 0.0001 0.001	@ -90°C 0.00008	@ -90°C 0.00008 0.0006
Gain (counts/e⁻):				
Standard Mode	1	1	0.6	0.6 1
High Capacity Mode	-	0.34	0.2	0.2 0.34
CCD sensor type	Front-illuminated (FI), Back-illuminated (BI), Deep depletion fringe suppression (DD), Enhanced back-illuminated (BI UV1)			
Blemish specifications	Grade 0 or Grade 1 (standard) as specified by sensor manufacturer. For more information please see: www.greateyes.de/en/glossar.html			

STEP 2: Select interface vacuum flange

Order Code	Description
CF1	Knife-edge sealed CF DN63 flange with threaded holes (only for 1k1k or 2k2k)
CF2	Knife-edge sealed CF DN100 flange with through holes (only for 1k1k or 2k2k)
CF3	Knife-edge sealed CF DN160 flange with through holes
CF4	Rotatable, knife-edge sealed CF DN100 flange with through holes (only for 1k1k or 2k2k)

We also provide quick release, rotatable, and other flanges of various sizes - please let us know your requirements

STEP 3: Choose your accessories and software

Order Code	Description
Accessories for Imaging Purposes	
GE-SR25	25mm shutter for 1k1k camera, including shutter driver module
GE-SR45	45mm shutter for 2k2k & 2k2k plus cameras, including shutter driver module
GE-AE01	Additional CF DN63 flange with a window of Beryllium, MgF2, UVFS or other materials, can be sealed with the camera flange, with a port for external vacuum pump, enables ALEX to be used in air independently
Accessories for Enhanced Cooling Performance	
GE-CR01	Compact liquid cooling, circulating the coolant at room temperature for deep camera cooling
GE-CR02	Recirculating water chiller, PID control with temp. from -5°C to 30°C for ultra-deep camera cooling
Software Development Kit (SDK) and Drivers	
GE-LX01	SDK for Linux (C/C++ based)
GE-PYT01	Python driver
GE-LAB01	LabVIEW driver
GE-EP	EPICS driver
GE-TAN	Tango driver

STEP 4: Flexible customisation service

With direct and fast response, we provide various customisations and OEM services. For example, other sensor types, the alteration of sensor position/tilt, the modification of camera housing or cooling system, etc. Let us know what **ALEX** you require.

TECHNICAL DRAWINGS

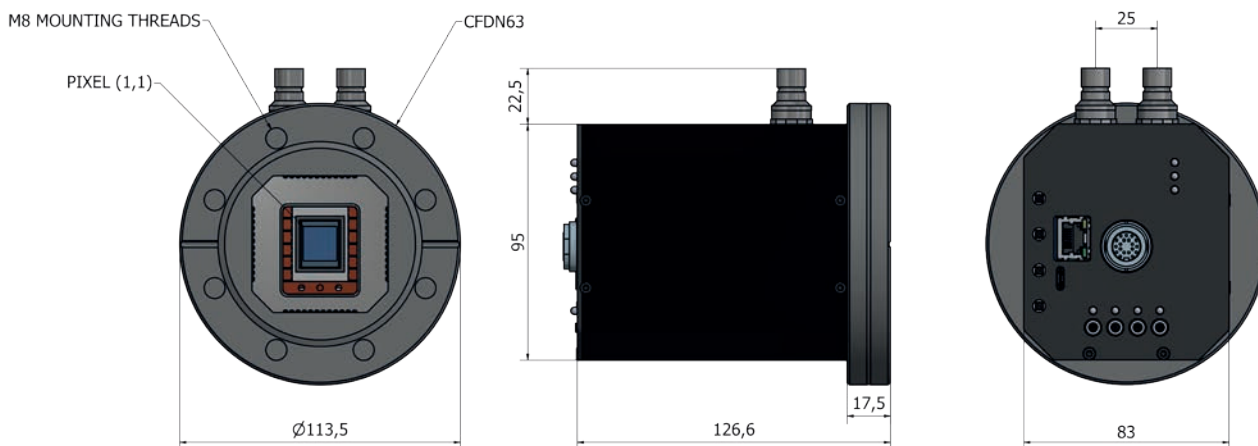

Pembroke Instruments, LLC
 San Francisco, California
sales@pembrokeinstruments.com
<https://pembrokeinstruments.com>
 Tel. 650-550-8618

Find a distributor or representative



Follow us on LinkedIn



Subscribe to our newsletter

